

Operating Instructions GenPure Ultrapure Water Systems

- | | |
|---|--|
| <input type="checkbox"/> Art. No.: 08.2202 (Standard) | <input type="checkbox"/> Art. No.: 08.2203 (UF) |
| <input type="checkbox"/> Art. No.: 08.2204 (UV/UF) | <input type="checkbox"/> Art. No.: 08.2205 (UV) |
| <input type="checkbox"/> Art. No.: 08.2206 (UV-TOC) | <input type="checkbox"/> Art. No.: 08.2207 (UV-TOC/UF) |



Serial number: _____

Read these operating instructions carefully before installing and starting the system!

29.0051; State: 07.09 Information given is not binding. Rights reserved for technical changes.

Company name and address
TKA Wasseraufbereitungssysteme GmbH
Stockland 3
D-56412 Niederelbert

EEC Declaration of Conformity

According to EEC Directive 98/37/EEC
- Machine Directive -

We herewith declare that, in their design and construction and in the versions that we have introduced into the market, the products named below conform to the fundamental safety and health requirements of

EEC Directive 98/37/EEC.

This declaration becomes invalid when changes that have not been explicitly agreed to by us are made to the machines.

Description of the machine:	Ultrapure water system
Machine types:	GenPure GenPure UV GenPure UF GenPure UV/UF GenPure UV-TOC GenPure UV-TOC/UF
Applicable EEC Directives:	EEC Machine Directive (98/37/EEC) EEC Low Voltage Directive (2006/95/EC) EEC Electromagnetic Compatibility Directive (2004/108/EC)
Applied Standards:	DIN EN ISO 12100-1 DIN EN ISO 12100-2 DIN EN 1050 DIN EN 60204-1 DIN EN 55011 DIN EN 50082-2

Niederelbert, 25th March 2004

Authorized Representative of the Manufacturer

Preface

Dear Sir or Madam

Thank you for the confidence you have placed in us by deciding to purchase a GenPure ultrapure water system.

You have selected a high quality product designed to give long and reliable service.

Before you start to install and commission your GenPure system, please carefully read through the information given in this operating instructions manual on installation and operation.

This is important as we, the manufacturer of the system, cannot be held liable for any damage occurring as a result of incorrect operation of it, or use of it for other than the intended purpose.

Niederelbert, 1st September 2004

1. Contents

Preface.....	3
1. Contents.....	4
2. Notes on the Operating Instructions	6
3. Transport and packaging	7
3.1 Examination on receipt.....	7
3.2 Complaints	7
3.3 Packing for return	7
4. Safety precautions	8
5. Intended purpose	9
5.1 Application areas.....	9
6. Parts standardly supplied.....	10
7. Technical specifications	12
8. Description of how the systems function.....	14
8.1 Flow chart for GenPure Standard.....	15
8.2 Flow chart for GenPure UV	16
8.3 Flow chart for GenPure UF	17
8.4 Flow chart for GenPure UV/UF	18
8.5 Flow chart for GenPure UV-TOC	19
8.6 Flow chart for GenPure UV-TOC/UF.....	20
9. Installation.....	21
9.1 The installation area	21
9.2 Installing the system.....	22
9.3 Installation examples.....	23
10. Commissioning the GenPure system.....	25
11. The control panel	26
12. The system control.....	27
12.1 The User-menu	28
12.1.1 Feedwater conductivity:	28

12.1.2. Ultrapure water limiting value:.....	28
12.1.3. UV-Lamp operating time and intensity:	29
12.1.4. Filter cartridge operating hours counter:	29
12.1.5. Rinsing procedure	29
12.1.6. Disinfection procedure	30
12.1.7. Fault storage display:.....	31
12.1.8. Unlocking the system	32
12.2. The OEM-Menu:	35
12.2.1. Set the limiting value for temperature:	35
12.2.2. Set the rinsing time:	36
12.2.3. Change the disinfection time:.....	36
12.2.4. Set the pump interval time:	36
12.2.5. Set the rinse interval time:.....	37
12.2.6. Adjust the real time clock:	37
12.2.6. Set the sending interval:.....	37
12.2.7. Select the language:	38
12.2.8. Switch units, conductivity/resistance:.....	38
12.2.9. Switch temperature compensation on/off:.....	38
12.3. Using volume control for water dispensing	39
12.4. Printer output	39
12.4.1. Standard message	39
12.4.2. Code message	40
12.4.3. Error message.....	40
13. Maintenance.....	41
13.1. Change the Filter cartridge	42
13.2. Disinfection procedure	43
14. Faults – Causes - Remedies	45
15. Replacement parts and consumables	48
16. Accessories	49
17. Terminal assignment	50
18. Maintenance record.....	51

2. Notes on the Operating Instructions



Potential hazards are highlighted by a warning triangle.



Particularly important notes are indicated by the “i” for information sign.

Information given in these Operating Instructions is only valid for the GenPure system whose serial number is entered on the front page..



Please write the serial number* of your GenPure system on the appropriate line on the front page of this Operating Instructions manual.

It is important that you correctly give:

- **the serial number* of your GenPure system**
- **the article number of your GenPure system**

whenever you contact us for information on your system or order consumables or replacement parts.

* The serial number is printed on the type plate attached to your GenPure system.

3. Transport and packaging

TKA Ultrapure water systems are carefully controlled and packed, but despite this damage could occur during transport.

3.1 Examination on receipt

- Check complete delivery by comparing the parts supplied with those listed in the delivery note.



Is the packaging visibly damaged?

- Inspect the equipment supplied for damage.

3.2 Complaints

Should damage have occurred during transport:

- Immediately* contact the postal, railway, shipping or air freight agent.
- Save the complete packaging (outer carton and packaging materials) for possible inspection or return delivery.

3.3 Packing for return

Whenever possible, use the original carton and packaging material.

Should these no longer be available, or be unfit for use:

- Pack the equipment in suitable sheets or bags in a strong cardboard box so that all parts are protected against shock.



- * **The time limit for claims is 6 days after the date of delivery.**
All rights to claim for damages cease when this time limit has elapsed.

4. Safety precautions

- Your GenPure system is an advanced system that has been designed exclusively for the production of ultrapure water from potable water that has been pretreated by reverse osmosis, ion exchange or distillation.
- Do not start to install or operate the system until you have heeded the corresponding information contained in these Operating Instructions.
- Do not make changes to the system. Please note that the manufacturer's liability does not cover damages resulting from improper operation or from use other than for the intended purpose.
- Protect the system from frost. The temperature at the installation area must not go below + 2°C.
- Follow all general regulations and requirements that must be observed at the installation location, including the valid accident prevention regulations.
- A feedwater pressure of min. 0.1 bar and max. 6 bar is required. Install an additional pressure reducer should the feedwater pressure be higher.
- DIN EN 1717 requires that water purification systems be equipped with a safety device that protects the drinking water system from contamination.
- An earthed 230 V / 50 Hz socket must be available.
- A floor drain with at least DN 50 pipe (38.5 mm internal diameter) must be available at the installation area. Should no such floor drain be available, then we recommend that a Water Watcher (Article No. 16.0129) be installed for reasons of safety, otherwise the manufacture cannot be held liable for damage caused by water.
- When the system is to be wall-mounted, check the statics of the wall for sufficient load-bearing capacity (see Technical Data for the weight of your system).
- The maximum operating temperature is 35°C.
- When the system will be at a standstill for a longer period (e.g. overnight, at the weekend or during annual holidays), proceed as follows:
 - **Switch the system off.**
 - **Close the supply of feedwater to the ultrapure water system.**Damage to the pump will occur should the supply of feedwater be turned off with the system still on. The manufacturer does not accept liability should such damage occur.
- When planning the installation of the system, ensure that there will be sufficient working room for convenient operation of the system and for maintenance such as changing the Filter cartridge and opening, breaking and checking connections.
- The guarantee is valid for a period of 12 months.
- Ultraviolet light can impair eyesight. The UV-lamp is therefore only to be replaced by TKA, or by service technicians who have been expressly authorized by TKA to do so.



For your own safety, please observe the above safety precautions!

5. Intended purpose

Increasingly sophisticated technologies, continually lower detection limits in laboratory analysis, and the requirement for biologically-pure water in research correspondingly require the water used to be of ever higher quality. The novel GenPure line of water purification systems has been developed to produce such ultrapure water, as well as to fill the needs for user-friendly systems and complete solutions

GenPure ultrapure water systems produce salt-free, organically-pure particle-free and sterile filtered ultrapure water.

To make full use of the long and economical service life of the high-quality purification media, the feedwater for GenPure systems must be pretreated by an appropriate purification step (reverse osmosis, ion exchange or distillation).

5.1 Application areas

- Analytical methods:

- HPLC (High Performance Liquid Chromatography)
- IC (Ion Chromatography)
- ICP (Inductive Coupled Argon Plasma)
- AAS (Atomic Absorptions Spectrophotometry)
- TOC-measurements (Total Organic Carbon)
- DNA research
- etc.

- Preparation of reagents and solutions:

- Cell culture media
- Tissue culture media
- In-vitro fertilization
- Make-up water for reagents for online analyzers

- Ultraclean washing and rinsing processes in laboratories

6. Parts standardly supplied

The following GenPure versions are available:

GenPure	(Standard system)
GenPure UF	(Standard system + Ultrafiltration module)
GenPure UV	(Standard system + UV-photooxidation)
GenPure UV/UF	(Standard system + UV-photooxidation + Ultrafiltration module)
GenPure UV-TOC	(Standard system + UV-photooxidation with TOC-measurement)
GenPure UV-TOC/UF	(Standard system + UV-photooxidation with TOC-measurement + Ultrafiltration module)

(Please check that the version you have received corresponds to that stated on the delivery note.)

Art.-No. 08.2202 consists of:

GenPure Standard basic unit

Material for wall-mounting	
Connecting hose, 1.5 m, straight/angle	(Article-No. 18.0042)
Sterile filter capsule, 0.2 µm	(Article-No. 09.1003)
Filter cartridge for ultrapure water systems	(Article-No. 09.2005)
PE hose, 8 mm OD, 2 m	(Article-No. 18.0036)
Operating Instructions manual	(Article-No. 29.0051)

Art.-No. 08.2203 consists of:

GenPure UF basic unit

Material for wall-mounting	
Connecting hose, 1.5 m, straight/angle	(Article-No. 18.0042)
Sterile filter capsule, 0.2 µm	(Article-No. 09.1003)
Filter cartridge for ultrapure water systems	(Article-No. 09.2005)
PE hose, 8 mm OD, 2 m	(Article-No. 18.0036)
Operating Instructions manual	(Article-No. 29.0051)

Art.-No. 08.2205 consists of:

GenPure UV basic unit

Material for wall-mounting	
Connecting hose, 1.5 m, straight/angle	(Article-No. 18.0042)
Sterile filter capsule, 0.2 µm	(Article-No. 09.1003)
Filter cartridge for ultrapure water systems	(Article-No. 09.2005)
PE hose, 8 mm OD, 2 m	(Article-No. 18.0036)
Operating Instructions manual	(Article-No. 29.0051)

Art.-No. 08.2204 consists of:

GenPure UV/UF basic unit

Material for wall-mounting	
Connecting hose, 1.5 m, straight/angle	(Article-No. 18.0042)
Sterile filter capsule, 0.2 µm	(Article-No. 09.1003)
Filter cartridge for ultrapure water systems	(Article-No. 09.2005)
PE hose, 8 mm OD, 2 m	(Article-No. 18.0036)
Operating Instructions manual	(Article-No. 29.0051)

Art.-No. 08.2206 consists of:

GenPure UV-TOC basic unit

Material for wall-mounting	
Connecting hose, 1.5 m, straight/angle	(Article-No. 18.0042)
Sterile filter capsule, 0.2 µm	(Article-No. 09.1003)
Filter cartridge for ultrapure water systems	(Article-No. 09.2005)
PE hose, 8 mm OD, 2 m	(Article-No. 18.0036)
Operating Instructions manual	(Article-No. 29.0051)

Art.-No. 08.2207 consists of:

GenPure UV-TOC/UF basic unit

Material for wall-mounting	
Connecting hose, 1.5 m, straight/angle	(Article-No. 18.0042)
Sterile filter capsule, 0.2 µm	(Article-No. 09.1003)
Filter cartridge for ultrapure water systems	(Article-No. 09.2005)
PE hose, 8 mm OD, 2 m	(Article-No. 18.0036)
Operating Instructions manual	(Article-No. 29.0051)

7. Technical specifications

Required quality of the feedwater	
Source and treatment	Potable water that has been pretreated by reverse osmosis, ion exchange or distillation.
Colloid index (SDI)	max. 1 for all versions. Additional upstream 1 µm membrane filtration is recommended for feedwater that has not been pretreated by reverse osmosis.
Feedwater conductivity	< 2 µS/cm
Free chlorine	max. 0.05 ppb
TOC	max. 50 ppb
Bacteria	< 100 CFU/ml
Turbidity	< 1.0 NTU
Carbon dioxide (CO ₂)	max. 30 ppm
Silicate	max. 2 ppm
Particles	Filtration to 0.2 µm is recommended to protect internal media and filters from fine particles.
Temperature	2 - 35 °C
Pressure	0.1 - 6 bar

Product water quality							
		Standard	UV	UF	UV/UF	UV-TOC	UV-TOC/UF
Resistance (Reference temperature 25°C)	MΩxcm at 25°C	18.2	18.2	18.2	18.2	18.2	18.2
TOC	ppb	5 - 10	1 - 5	5 - 10	1 - 5	1 - 5	1 - 5
Bacteria	CFU/ml	< 1	< 1	< 1	< 1	< 1	< 1
Bacterial Endotoxines	EU/ml	--	--	< 0.001*	< 0.001*	--	< 0.001*
Particles	> 0.2 µm	< 1/ml	< 1/ml	< 1/ml	< 1/ml	< 1/ml	< 1/ml
Flow rate	L/min**	up to 2	up to 2	up to 1.7	up to 1.7	up to 2	up to 1.7
Flow rate with volume control	L/min	1.2	1.2	1.2	1.2	1.2	1.2

* Depending on feedwater and appropriate disinfection

** Depending on feedwater pressure

Dimensions and weight	
Height	615 mm
Width	372 mm
Depth	330 mm
Weight:	
GenPure Standard	22 kg
GenPure UF	23 kg
GenPure UV	23 kg
GenPure UV/UF	24 kg
GenPure UV-TOC	24 kg
GenPure UV-TOC/UF	25 kg

Cell constants of the measuring cells	
Feedwater conductivity	0.16 cm ⁻¹
Conductivity after UV-oxidation	0.01 cm ⁻¹
Ultrapure water conductivity	0.01 cm ⁻¹

Water connections	
Feedwater	R 3/4"
Rinse water	8 mm OD hose
Ultrapure water	R 1/4"
Sterile filter outlet	8 - 10 mm OD hose

Electrical connections	
Voltage	230 V
Frequency	50/60 Hz
Power consumption	approx. 100 W
Serial interface	RS 232

Materials of parts that contact water	
Pressure reducer	NBR
Pump head	Nylon with glass fibre
UV-Lamp	Ultrapure quartz
UV-Housing	Stainless steel
Ion exchanger	PP
UF-Housing	Polycarbonate
Rinsing solenoid valve	PA
Dispensing valve	PVDF
Conductivity measuring cell	POM, stainless steel
Distributor block	POM
Connectors	POM
Hoses	PE
Gaskets	EPDM

8. Description of how the systems function

GenPure Standard, UV, UF and UV/UF versions

Potable water is pretreated by a downstream reverse osmosis, ion exchange system or distillation, then fed through a pressure reducer into the GenPure ultrapure water system, where the conductivity of it is measured. A pump forces this feedwater through a UV-photooxidation (only with GenPure UV and GenPure UV/UF) and a Filter cartridge, then through an ultrafiltration module. (only with GenPure UF and GenPure UV/UF), following which the conductivity is permanently measured by a special measuring cell (with temperature compensation). When the dispensing valve is opened, the ultrapure water is subjected to filtration by a sterile filter immediately prior to flowing out of the ultrapure water outlet. When the system is in stand-by mode (the Interval operating state), the water in the system is recirculated through the internal circuit at regular intervals.

GenPure UV-TOC and UV-TOC/UF versions

Potable water is pretreated by a downstream reverse osmosis, ion exchange system or distillation, then fed through a pressure reducer into the GenPure ultrapure water system, where the conductivity of it is measured. A pump forces this feedwater through a UV-photooxidation, following which the conductivity of the water is measured for the TOC determination, and on through a Filter cartridge and an ultrafiltration module (only with GenPure UV-TOC/UF), and the conductivity is then permanently measured by a special measuring cell (with temperature compensation). When the dispensing valve is opened, the ultrapure water is subjected to filtration by a sterile filter immediately prior to flowing out of the ultrapure water outlet. When the system is in standby mode (the Interval operating state), the water in the system is recirculated through the internal circuit at regular intervals.

8.1 Flow chart for GenPure Standard

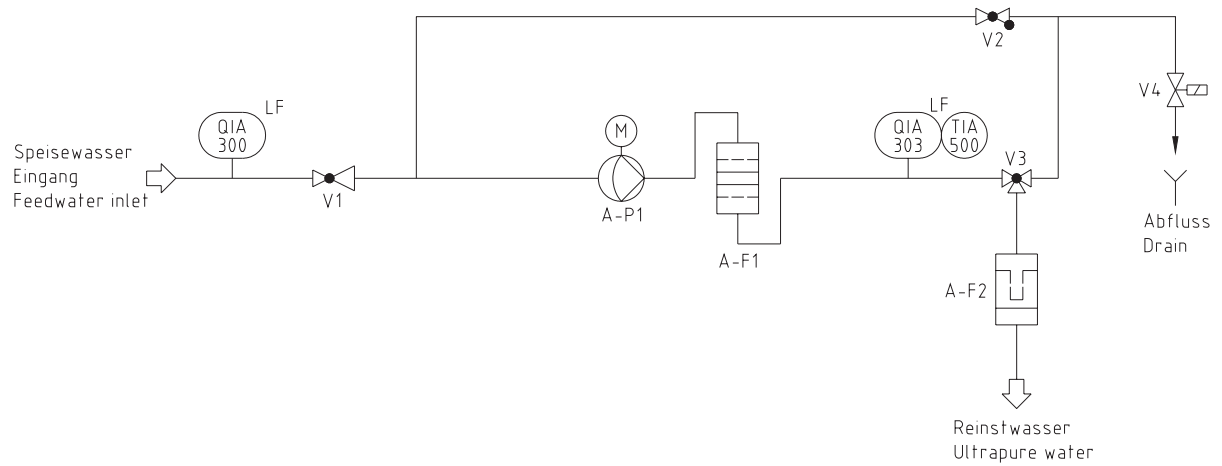

A-F1	Filter cartridge
A-F2	Sterile filter
A-P1	Circulation pump
QIA 300	Feedwater conductivity measuring cell
QIA 303	Ultrapure water conductivity measuring cell
TIA 500	Temperature sensor
V1	Pressure reducer
V2	Check valve
V3	Dispensing valve
V4	Rinsing solenoid valve

8.2 Flow chart for GenPure UV

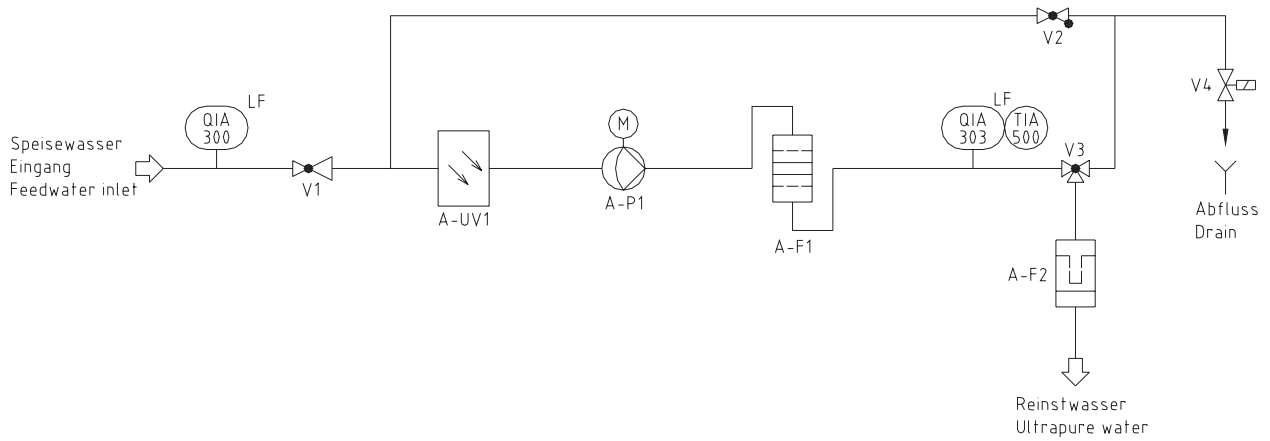

A-F1	Filter cartridge
A-F2	Sterile filter
A-P1	Circulation pump
A-UV1	UV-photooxidation
QIA 300	Feedwater conductivity measuring cell
QIA 303	Ultrapure water conductivity measuring cell
TIA 500	Temperature sensor
V1	Pressure reducer
V2	Check valve
V3	Dispensing valve
V4	Rinsing solenoid valve

8.3 Flow chart for GenPure UF

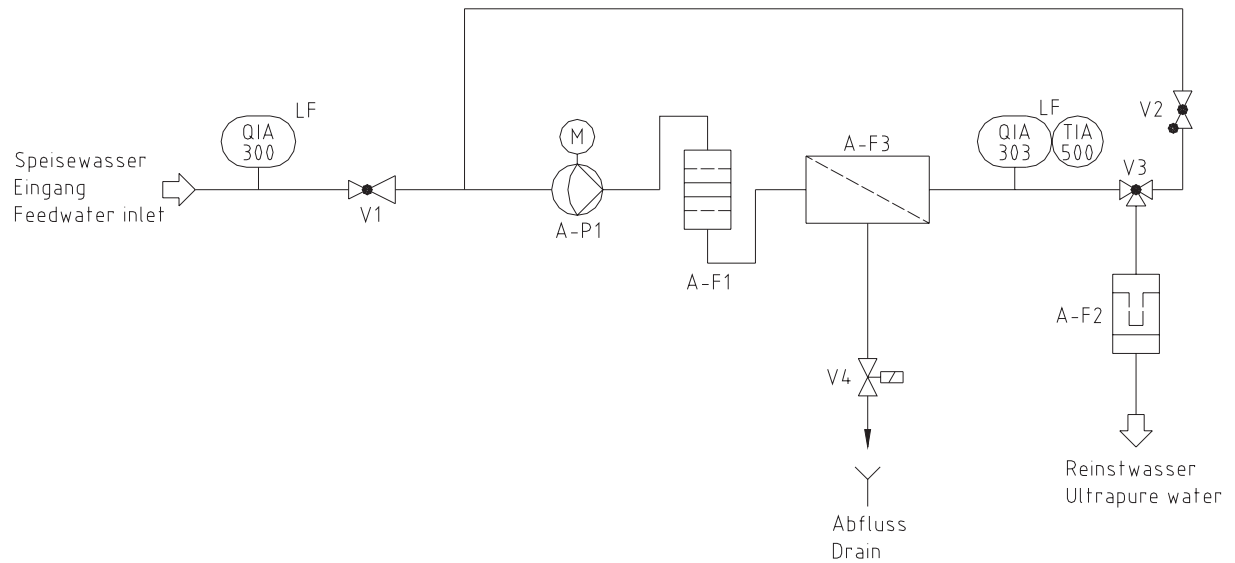

A-F1	Filter cartridge
A-F2	Sterile filter
A-F3	Ultrafiltration module
A-P1	Circulation pump
QIA 300	Feedwater conductivity measuring cell
QIA 303	Ultrapure water conductivity measuring cell
TIA 500	Temperature sensor
V1	Pressure reducer
V2	Check valve
V3	Dispensing valve
V4	Rinsing solenoid valve

8.4 Flow chart for GenPure UV/UF

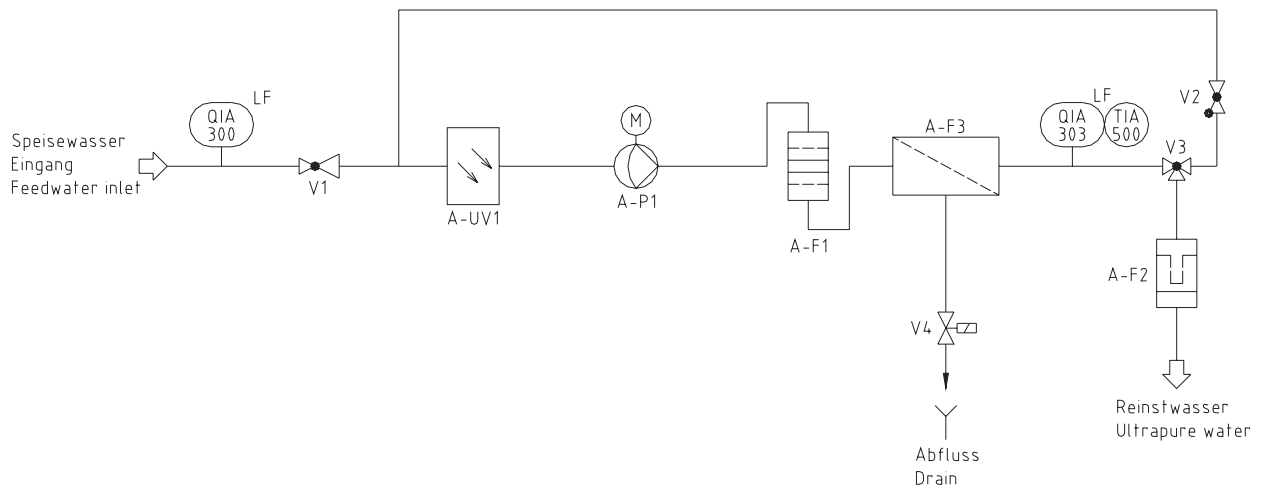

A-F1	Filter cartridge
A-F2	Sterile filter
A-F3	Ultrafiltration module
A-P1	Circulation pump
A-UV1	UV-photooxidation
QIA 300	Feedwater conductivity measuring cell
QIA 303	Ultrapure water conductivity measuring cell
TIA 500	Temperature sensor
V1	Pressure reducer
V2	Check valve
V3	Dispensing valve
V4	Rinsing solenoid valve

8.5 Flow chart for GenPure UV-TOC

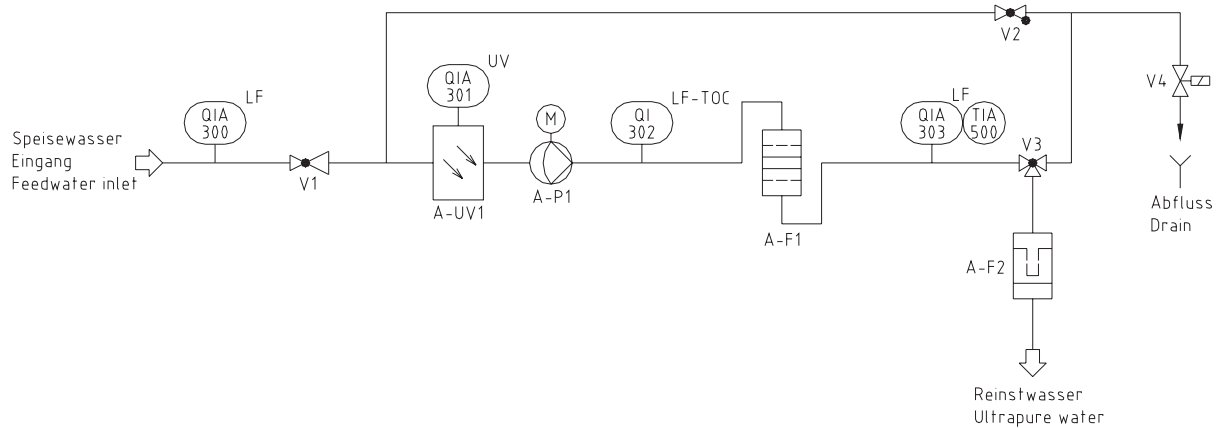

A-F1	Filter cartridge
A-F2	Sterile filter
A-P1	Circulation pump
A-UV1	UV-photooxidation
QIA 300	Feedwater conductivity measuring cell
QIA 301	UV-Intensity
QI 302	Conductivity for TOC-measurement
QIA 303	Ultrapure water conductivity measuring cell
TIA 500	Temperature sensor
V1	Pressure reducer
V2	Check valve
V3	Dispensing valve
V4	Rinsing solenoid valve

8.6 Flow chart for GenPure UV-TOC/UF

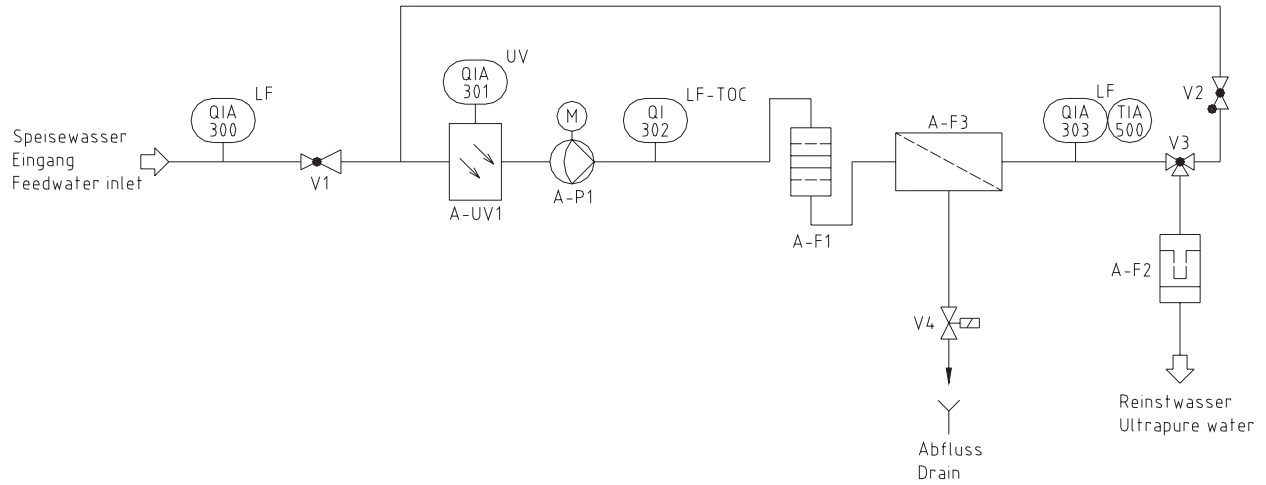

A-F1	Filter cartridge
A-F2	Sterile filter
A-F3	Ultrafiltration module
A-P1	Circulation pump
A-UV1	UV-photooxidation
QIA 300	Feedwater conductivity measuring cell
QIA 301	UV-Intensity
QI 302	Conductivity for TOC measurement
QIA 303	Ultrapure water conductivity measuring cell
TIA 500	Temperature sensor
V1	Pressure reducer
V2	Check valve
V3	Dispensing valve
V4	Rinsing solenoid valve

9. Installation

9.1 The installation area

The following criteria must be considered when the installation area is selected:

- Feedwater pressure at least 0.1 bar, at most 6 bar.



The feedwater pressure must not exceed 6 bar. With higher pressures, a pressure reducer must be installed.

- Minimum temperature + 2°C
- Level standing surface
- When the system is to be wall-mounted, the wall surface must be smooth and the statics of the wall be checked for sufficient load-bearing capacity (weight, see Technical specifications)
- DN 50 floor drain
- Unrestricted gravity fall to the floor drain.
Should a floor drain not be available, install a Water Watcher (Article No.: 16.0129) to protect against water damage!



A free flow-off must be ensured!

- Earthed 230 V, 50 Hz socket
- Sufficient working room around the GenPure system (for Filter cartridge change, etc.)
- The system must be positioned for easy operation and control
- R 3/4" potable water tap connection

9.2 Installing the system

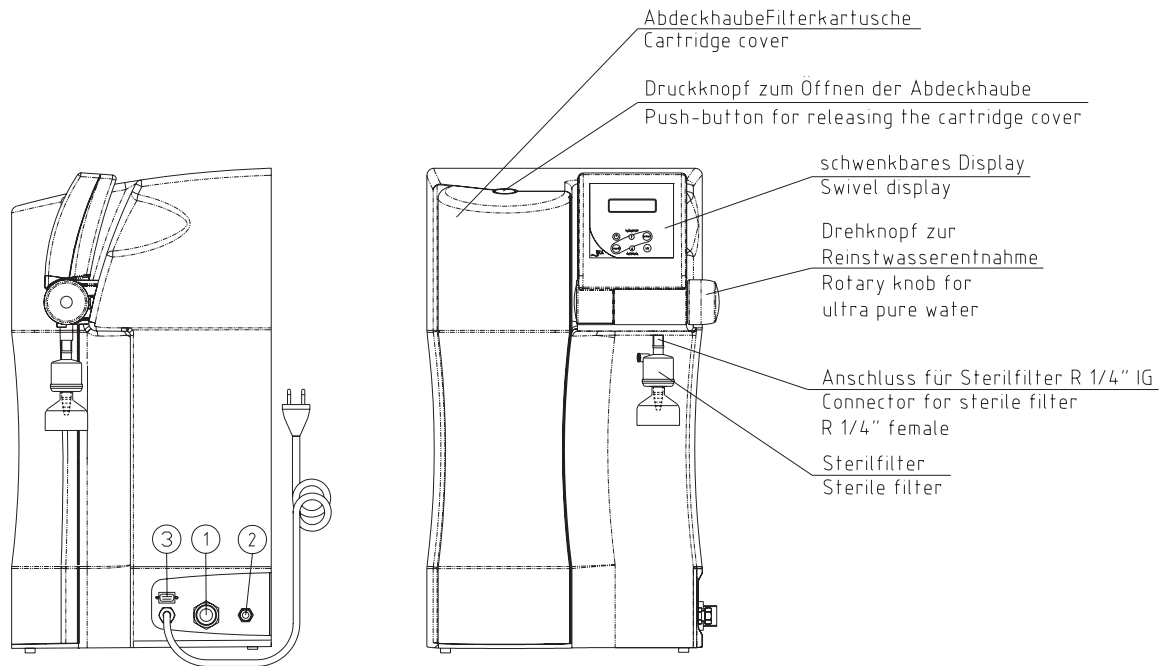

- 1) Feedwater inlet connector, R 3/4" male thread
- 2) Rinsing water outlet connector, 8 mm OD
- 3) Connector for an optional printer (Article No.: 09.2207)

Proceed as follows to prepare your GenPure ultrapure water system for operation:

- Stand the GenPure system on the selected surface or hang it on the wall using the hooks supplied.
- Remove the cartridge cover from the GenPure system (push-button on the top).
- Remove the closing caps from the Filter cartridge and save them for later use.
- Push the Filter cartridge in (guide in the recess), fit the quick-connect couplings on and put the cover back on.
- Fit the connecting hose to the GenPure system (connector 1) and to the feedwater connector (see the following Installation examples)
- Use the 8 mm OD hose to connect the GenPure system (connector 2) to the floor drain, ensuring free gravity fall to drain
- If not already fitted, screw the sterile filter provided into the R 1/4" female thread of the dispensing valve outlet.
- Plug the line cord into an earthed 230 V, 50 Hz socket.
- Open the feedwater tap.

9.3 Installation examples

Connection to a pretreatment unit:

Vorbehandlung 09.2000
nicht im Lieferumfang enthalten
Pretreatment 09.2000
not included in extent of delivery

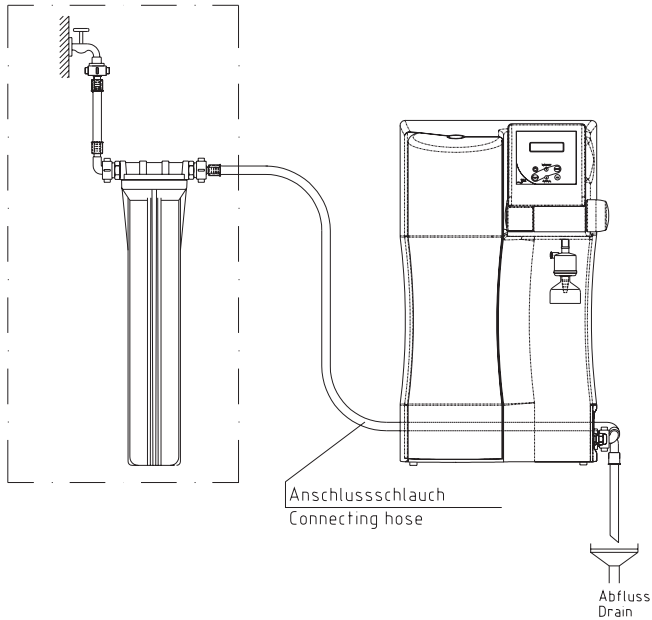

Connection to a TKA Pacific UP/UPW high purity water system via a storage tank:

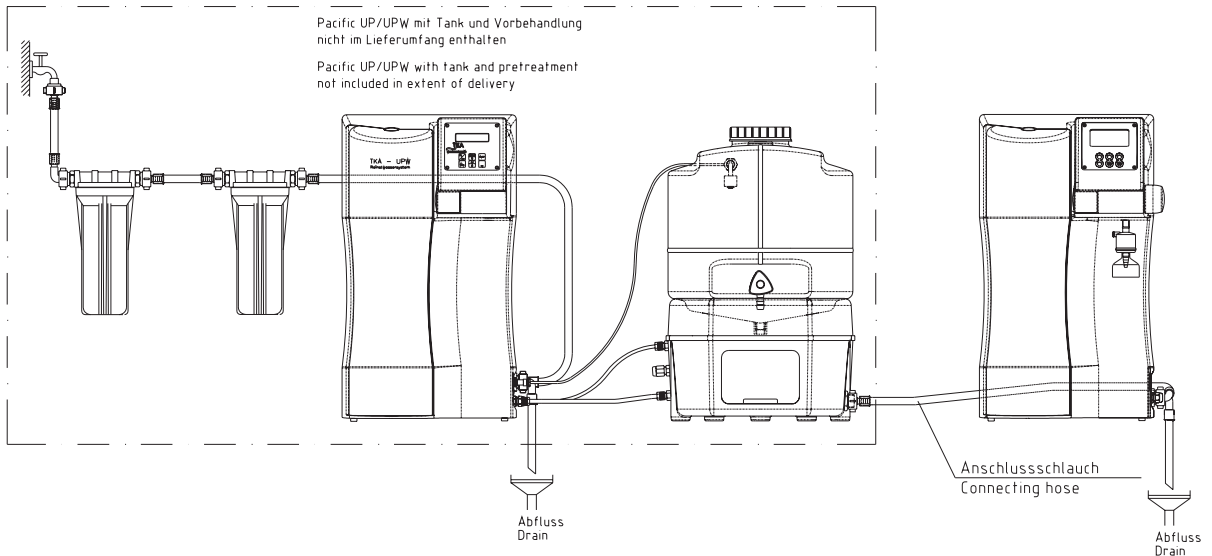

Connection to a storage tank:

Vorratstank für destilliertes Wasser
nicht im Lieferumfang enthalten
Storage tank for distilled water
not included in extent of delivery

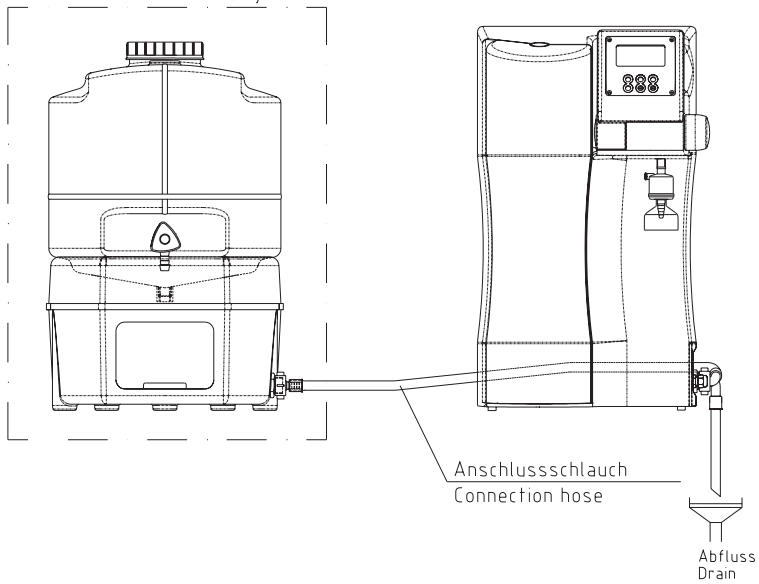

Caution: When connected to a TKA storage tank, the GenPure system must be switched to "Nonstop" operation when ultrapure water is to be dispensed.

10. Commissioning the GenPure system



Before starting the GenPure system up, check that it has warmed up or cooled down to room temperature.



Check that all corrections have been correctly made as described in the section „Installation“.



Switch the system on by pressing this key. After a compulsory internal rinse, the system switches to the operating state that was last set.



To air-vent the system, switch the system to „Rinse“ in the menu three times successively, and in each case use the dispensing valve to withdraw approx. 5 litres of water, which is to be discarded. The limiting value for the ultrapure water may be exceeded during this procedure.

NONSTOP



Switch the system to the „Nonstop“ operating state by pressing this “NONSTOP“-key.



INTERVAL

When the system is producing the ultrapure water quality that you require, you can return the system to “Interval“ operation by pressing this INTERVAL-key.

11. The control panel

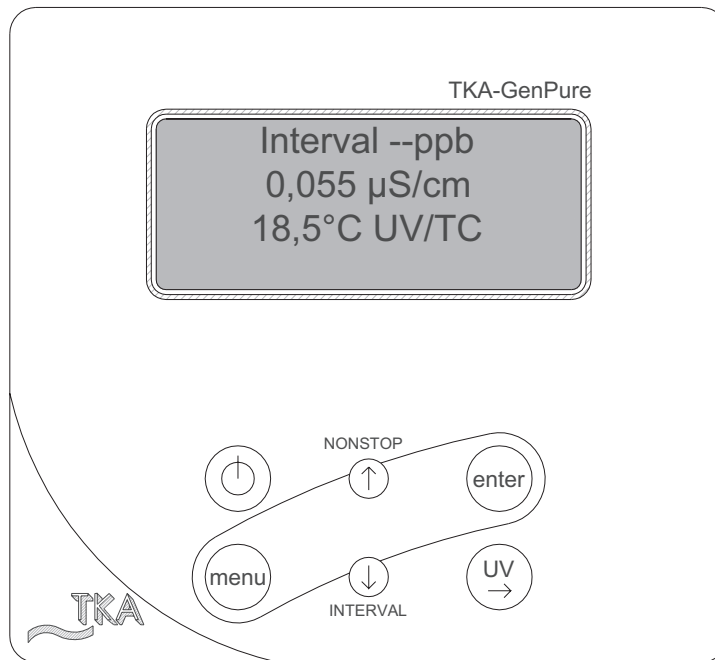

Switches the system on or off

NONSTOP



Switches "Nonstop" operation on or, in the menu, increases a value on display



Confirms the value shown in a menu point



Switches the menu to the next menu point



INTERVAL

Switches "Interval" operation on or, in the menu, decreases a value on display



Switches the UV-lamp on or, in the menu, allows you to select the position in a number that you wish to change

12. The system control

General information

A single press on the ON/OFF-key brings the system to the *Interval* operating state (see Interval operation). In this stand-by mode, recirculation within the system is automatically started every half hour, and lasts for the time set. This measure assures maintenance of the ultrapure water quality.

The text message "UV" indicates that the UV-lamp is switched on. The text message "TC" indicates that temperature compensation is switched on. In addition, the measured value of the ultrapure water and the temperature are displayed.

Should a fault occur, the corresponding fault message is transmitted via the potential-free output and is shown in clear text in the 4th line of the display. In the case of several faults occurring at one time, they are alternately shown in the display.

A press on the NONSTOP-key switches the system to *Nonstop* operation. The pump runs and the rinsing solenoid valve opens for the duration of the *Rinse interval* that has been set. A press on the INTERVAL-key stops *Nonstop* operation and switches the system to *Interval* operation. After 2 hours, the system switches itself automatically to *Interval* operation

When the UV-key is pressed, "UV" is shown in the display, but the UV-lamp is only actuated when the system is in the *Nonstop* operation state. It is automatically switched off when *Nonstop* operation is stopped after 2 h. When *Nonstop* operation is manually stopped by pressing the INTERVAL-key, the UV-lamp is not switched off until it has been burning for a minimum of 0.5 hours.

The intensity of the UV-light is monitored when the UV-lamp is actuated, and the measured value is shown in the display. The TOC-value is additionally shown.

The User-menu

All measured values, operating times and limiting values that are relevant for the user can be set and read here.

A press on the menu-key brings you into this menu. Each further press on the menu-key moves you from one menu point to the next.

Settings can be changed by pressing on the arrow-keys and be confirmed by pressing the enter-key, which also takes you to the next menu point. Settings can only be changed when the system control has been previously unlocked (see 12.1.8).

To simplify changing a value, a press on the UV-key allows you to select the position in a number which you wish to change, and then use the arrow keys to replace the digit there by any digit from 0 - 9.

Minimum and maximum measured values have been entered as limiting values in the fixed programme for each of the conductivity and temperature measuring cells. Should these measured values be gone below or exceeded, it can be assumed that a break in a cable has occurred. The fault message "Meas.cell LF1", "Meas. cell LF2", "Meas. cell LF3" or "Temp. Meas. cell" is shown in the 4th line of the display.

12.1 The User-menu

12.1.1 Feedwater conductivity:

A single press on the menu-key allows the feedwater conductivity to be read or the limiting value of it to be changed. The fault message „*Limit value feed*“ flashes in the 4th line of the display when the limiting conductivity value is exceeded.

Feedwater measuring range: 0.1- 99.9 $\mu\text{S/cm}$
Limiting value setting range: 0.1- 50.0 $\mu\text{S/cm}$
Basic setting: 2 $\mu\text{S/cm}$

When a setting above 50 $\mu\text{S/cm}$ is entered for the limiting value, the limiting value is switched off and the word „*Off*“ appears in the display.

The display shows:

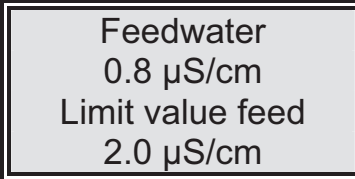

Feedwater
0.8 $\mu\text{S/cm}$
Limit value feed
2.0 $\mu\text{S/cm}$

12.1.2. Ultrapure water limiting value:

Two presses on the menu-key in this menu allow the fault display for the pure water limiting value and the pure water limiting value to be set. As soon as the fault display is switched on, the fault will be displayed both in Stand-by mode and in Production mode. When the fault display is switched off, the fault is only displayed in Production mode. The “Lim. val.pure w.” message is displayed when the limiting value is exceeded.

Ultrapure water measuring range: 9.999 $\mu\text{S/cm}$
Limiting value setting range: 0.055- 5.000 $\mu\text{S/cm}$
Basic setting: 0.1 $\mu\text{S/cm}$
Basic setting, fault suppression: On

When a setting above 5.0 $\mu\text{S/cm}$ is entered for the limiting value, the limiting value is switched off and the word „*Off*“ appears in the display.

The display shows:



Fault message
Stand- by On
Lim. val. pure w.
0.100 $\mu\text{S/cm}$

12.1.3. UV-Lamp operating time and intensity:

In this menu the operation hours of the UV-lamp are indicated and the evaluation of UV-sensor input into the display under "UV time".

The fault message "UV duration" is displayed when the maximum operating time has been reached.

The UV-sensor measures the intensity of the UV-light, and this is displayed as a percentage value of the maximum value.

The display shows:

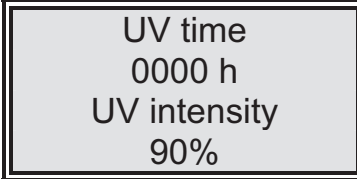

UV time
0000 h
UV intensity
90%

12.1.4. Filter cartridge operating hours counter:

After fourth press on the menu-key the operating hours counter for the filter cartridge is set by input of a valid serial number.

The display shows:



Ser. no.:
cartridge
Press enter
-----/--

12.1.5. Rinsing procedure

A fifth press on the menu-key calls the question asking if rinsing is to be carried out. A press on the enter-key confirms this and triggers the rinsing procedure. The pump starts and the rinsing solenoid valve opens for the rinsing time set in the OEM-menu.

The remaining rinsing time is shown in the display during rinsing

Neither fault messages nor measured values are displayed during rinsing.

When the rinsing procedure is finished, the system returns to the last operating state (Interval or Nonstop).

The display shows:

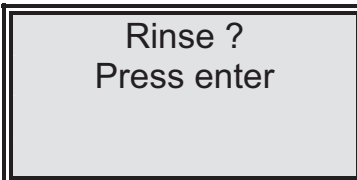

Rinse ?
Press enter

The display during rinsing:

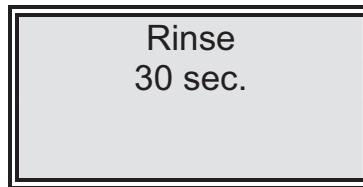

12.1.6. Disinfection procedure

A sixth press on the menu-key calls the question asking if a disinfection is to be carried out. A press on the enter-key confirms this, following which the demand "*Disinfection cartridge must be fitted*" is shown. When this has been fitted, a confirming press on the enter-key triggers the disinfection procedure. The pump starts for the full time set in the OEM-menu and, when the half of this time has elapsed, the rinsing solenoid valve opens and stays open until the disinfection procedure has finished. The demand "*New Filterset must be fitted*" is then displayed. When this has fitted, confirmation with the enter-key causes the system to return to the last operating state.

During disinfection the remaining disinfection time is shown in the display.

The display shows:

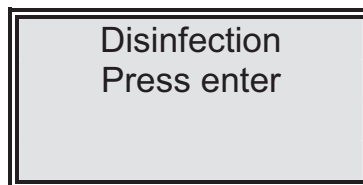

The display after confirmation with the enter-key:

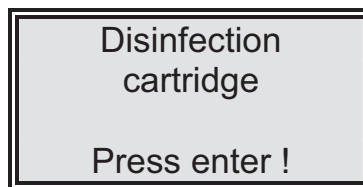

The display during the disinfection procedure:

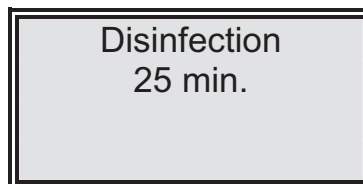

The display when disinfection has been completed:



New
filterset
Press enter

12.1.7 Fault storage display:

A seventh press on the menu-key calls the fault storage, and the contents of this can be examined by pressing the Enter-key.

Up to two faults are shown in the display, each with the date and time at which they occurred. Pressing the appropriate arrow key allows any fault messages before or after those shown to be called.

A press on the menu-key or on the Enter-key returns the system to the last operating state.

The display shows:

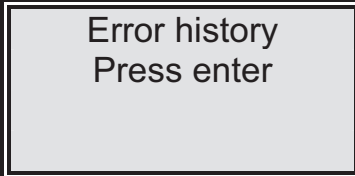

Error history
Press enter

The fault storage display:

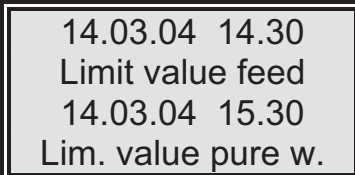

14.03.04 14.30
Limit value feed
14.03.04 15.30
Lim. value pure w.

12.1.8 Unlocking the system

A eight press on the menu-key calls the menu „Code“.

To prevent unauthorized access to the settings, changes to settings can only be made when a correct code number from the following Table is entered and confirmed with Enter. The unlocking is then active for a 5 minute period.

Each access via the code is printed out by the printer (RS 232) complete with date, time and shortened code number. ("Code 150" = Code 0001, "Code 250" = Code 0002 etc.)

The display shows:



You can assign the permissible code numbers listed in the Table on the following page to appropriate members of the staff etc. When names have been entered, tear the page out and file it where it is safe from unauthorized viewing.

**Table for assigning permissible code numbers
for unlocking the system**

Code-No.	printed out	Person
150	0001	
250	0002	
350	0003	
450	0004	
550	0005	
650	0006	
750	0007	
850	0008	
950	0009	

12.2 The OEM-Menu:

Basic settings and limiting values can be changed in this menu.
To make such changes in the OEM-menu, the system must first be unlocked (see 12.1.7).

Calling the OEM-menu:

Simultaneous presses on the INTERVAL-key and the NONSTOP-key call the OEM-menu. The display shows "OEM-Menu Press enter!". On confirming this by pressing the enter-key, the first menu point is called to be worked on. To simplify making changes, a press on the UV-key allows the position that is to be changed in a number to be selected, so that the arrow keys can be used to replace it with any digit from 0 – 9. A press on the menu-key takes you to the next menu point.

The display shows:

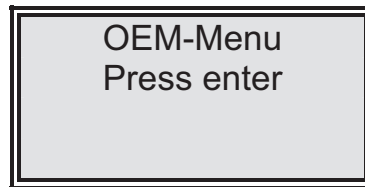

12.2.1 Set the limiting value for temperature:

The maximum operating temperature limit for the system is set here. Should this temperature be exceeded, the fault message „Max. temperature“ is triggered. This is shown in the 4th line of the display.

Basic setting: 50 °C
Setting range: 1 - 50 °C

The display shows:

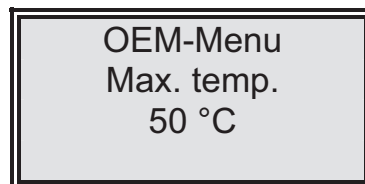

12.2.2 Set the rinsing time:

Basic setting: 30 sec.
Setting range: 10 - 60 sec.

The display shows:

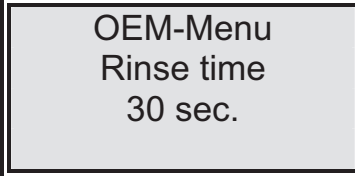
A rectangular box with a double border containing the text: OEM-Menu
Rinse time
30 sec.**12.2.3 Change the disinfection time:**

Basic setting: 30 min.
Setting range: 15 - 90 min.

The display shows:

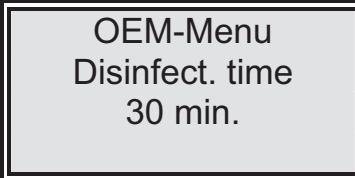
A rectangular box with a double border containing the text: OEM-Menu
Disinfect. time
30 min.**12.2.4 Set the pump interval time:**

Basic setting: 5 min.
Setting range: 1 - 30 min.

The display shows:

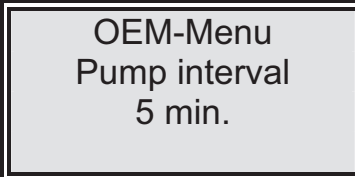
A rectangular box with a double border containing the text: OEM-Menu
Pump interval
5 min.

12.2.5 Set the rinse interval time:

Basic setting: 0.5 sec.
Setting range: 0.1 - 2 sec.

The display shows:

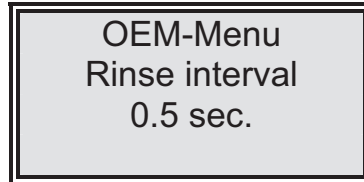

OEM-Menu
Rinse interval
0.5 sec.

12.2.6 Adjust the real time clock:

Basic setting: The actual date
Setting range: Month 1 - 12, Day 1 - 31, Hour 0 - 24, Minutes 0 - 60.

The display shows:

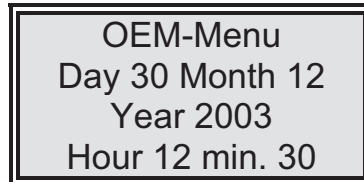

OEM-Menu
Day 30 Month 12
Year 2003
Hour 12 min. 30

12.2.6 Set the sending interval:

The sending interval at which measured values and fault messages are transmitted via the RS 232 interface can be set here.

Basic setting: 1 hour
Setting range: 0.5 - 12 hours

The display shows:

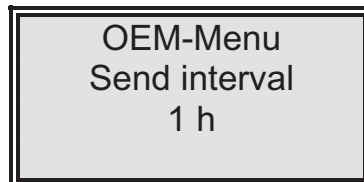

OEM-Menu
Send interval
1 h

12.2.7 Select the language:

Basic setting: German
Setting range: German, English, French

The display shows:

A rectangular display box with a double border containing the text: OEM-Menu
Language
English**12.2.8 Switch units, conductivity/resistance:**

Basic setting: Conductivity $\mu\text{S/cm}$
Setting range: Conductivity $\mu\text{S/cm}$, specific electrical resistance $\text{M}\Omega\text{ cm}$

The display shows:

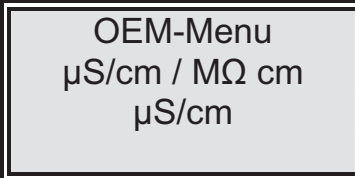
A rectangular display box with a double border containing the text: OEM-Menu
 $\mu\text{S/cm}$ / $\text{M}\Omega\text{ cm}$
 $\mu\text{S/cm}$ **12.2.9 Switch temperature compensation on/off:**

Basic setting: On
Setting range: On, Off

The display shows:

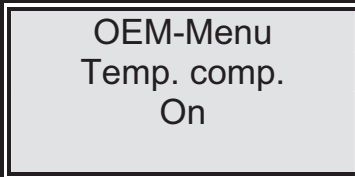
A rectangular display box with a double border containing the text: OEM-Menu
Temp. comp.
On

12.3 Using volume control for water dispensing

GenPure systems that are equipped with the option of volume control allow volume-controlled dispensing to be carried out.

As soon as the Nonstop operating mode is selected, the number of litres that were last required appears as set value in line 2 of the display.

Press once on the Enter-key if you wish to use the arrow keys to change this set value within the permissible range of 0.01 to 60 litres. You can use the UV-key to position the cursor at the position where you want to change the number.

Press twice on the Enter-key if you wish to have the displayed water volume dispensed. During dispensing, the number shows the actual volume dispensed. Dispensing is stopped as soon as the set value has been reached.

Dispensing can be stopped at any time by a further press on the Enter-key.

To carry out manual dispensing of volumes smaller than the set value, first press the Enter-key twice, then press it once again when the required volume has been dispensed.

The Display shows:

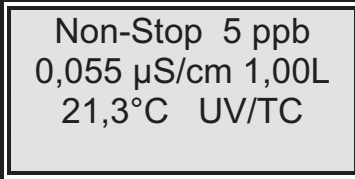

```
Non-Stop 5 ppb
0,055 µS/cm 1,00L
21,3°C UV/TC
```

12.4 Printer output

By means of the printer different parameters are documented. It is differentiated between three messages.

- Standard message
- Code message
- Error message

12.4.1 Standard message

Here in dependence of the transmit interval of all measured values are printed out. Within the NONSTOP-operation a complete data record is printed out.

Printout:

e. g.: 27.02.07 15:15
 GenPure Standard
 S.No. 3988/07
 Interv. TC on UV off
 LF1= 0.055 µS/cm
 LF2= 0.100 µS/cm
 LF3= 0.000 µS/cm
 Temp.= 16.8 °C
 TOC= 0 ppb
 UV Intens.= 0%

Standard protocol contains all measured values. With devices without TOC measurement and UV-intensity are spent the measured values with 0!

12.4.2 Code message

If a code number is entered into the system control and confirmed with the enter key, then the code input is printed out immediately. Code identification (see „tables of classification for authority codes for unlocking the system“).

Printout:

e. g.: 27.02.07 15:17
 GenPure Standard
 S.No. 3988/07
 Code 0002

12.4.3 Error message

If an error message in the display, e.g. the high-purity water limit value is indicated, the error message is printed out after the transmit interval.

Printout:

e. g.: 27.02.07 17:09
 GenPure Standard
 S.No. 3988/07
 Reinst.grenzwert

13. Maintenance

Regular maintenance maintains the value of your system. We recommend that you close a service contract with the **TKA** representative authorized to service your area. You then have the certainty that your system is kept at a high level of operational safety and reliability.

NOTE!

If your system is to work reliably for a long time, it must be controlled, maintained and cared for at regular intervals in accordance with the information given in these operating instructions! These operating instructions must therefore be kept readily available to operating and maintenance staff at all times, and the staff must carefully follow them!

Please note that, in accordance with **TKA** general business terms and conditions which are the basis for both parties, the guarantee is invalidated when the system is improperly installed, maintained, repaired, operated or changed by the customer or a third party, or is operated in an environment which does not fulfil the installation requirements specified by **TKA**.

Any maintenance work that is necessary during the period of the guarantee is only to be carried out by **TKA** or by a customer service company expressly authorized by **TKA** to do so.

It is the duty of the operating staff to carry out the weekly controlling of the system. During the period agreed upon for the guarantee, maintenance is to be carried out weekly according to the maintenance record provided in this operating instruction manual.

Should the maintenance record not be properly kept, i.e. without the necessary recording of data, then the system will be deemed to be inadequately maintained, and the guarantee becomes invalid.

IMPORTANT!

Ion exchangers should be regenerated and internally cleaned when the ultrapure water limiting value is exceeded. Longer usage can be result in bacterial growth on the resin.

The ultrafiltration membrane should be replaced once per year for optimal function to be ensured.

Sanitization of the system by the performance of rinsing and disinfection is carried out for reasons of hygiene and has no effect on the technical condition of the system.

The system need only be rinsed and disinfected when algae or slime is determined in it, otherwise at least once per year.



Prior to carrying out control or maintenance work on electrical equipment, the mains power supply must be switched off and protected against being unwantedly switched on again. Such work is only to be performed by assigned skilled technicians.

13.1 Change the Filter cartridge



The filter cartridge must be replaced as soon as the maximum limiting value set for the ultrapure water is exceeded or when the “Change cartridge” message is shown in the display.

Proceed as follows to replace the Filter cartridge:

1. Switch the system off.
2. Shut off the supply of feedwater.
3. Open the dispensing valve until the flow of water stops, then re-close it.
4. Remove the cartridge cover.
5. Disconnect the quick-connects on the feedwater inlet and purified water outlet of the cartridge, then close the inlet and outlet with the stoppers which you have kept for later usage.
6. Draw the used Filter cartridge out from the guide and insert the new Filter cartridge.
7. Remove the stoppers from the new Filter cartridge and store them for later use.
8. Plug the quick-connects correctly onto the new Filter cartridge.
9. Replace the cartridge cover.
10. Open the supply of feedwater.
11. Switch the system on again.
12. Run off and discard at least 5 litres of water.
13. To return the operating time meter to zero, enter the serial number that is given on the cartridge as described in the “Filter cartridge operating hours counter” section.
Important: To do this, the system must first be unlocked via the code function, refer here to the "Unlocking the system" section.



To air-vent the system, switch it to the „Rinse“ state.

13.2 Disinfection procedure



Disinfection should be regularly carried out, at the latest when the Filter cartridge is replaced.

A TKA disinfection cartridge (article no.: 09.2201) is required for disinfection of the system.

MICRO-Chlor disinfectant (article no.: 09.2202) are to be used as disinfectant.



To avoid possible health hazards, please take notice of the information given in the safety data sheet supplied in the packaging when handling MICRO-Chlor!

Proceed as follows to sanitize your system:

1. Switch the TKA GenPure system off.
2. Shut off the supply of feedwater to the system and open the dispensing valve so that pressure in the system is completely released.
3. Remove the filter cartridge (as under "Changing the filter cartridge").
4. Unscrew the stopper from the disinfectant cartridge, fill the cartridge with water then empty the contents of a MICRO-Chlor container into the water.
Important! For effective disinfection the cartridge must be completely filled with water.
- 5.
6. Screw the stopper back on the disinfectant cartridge and connect the cartridge in the system (as under "Changing the filter cartridge").
7. Re-open the feedwater supply.
8. Switch the system on and select the "Disinfection" prompt in the menu. The disinfection programme is finished after approx. 30 minutes.
9. Switch the system off.
10. Shut off the supply of feedwater to the system.
11. Remove the disinfectant cartridge (as under "Changing the filter cartridge").
12. Connect the new filter cartridge in the system (as under "Changing the filter cartridge").



Before dispensing water from the system, let water run out for approx. 15 minutes. The system is then ready for use.

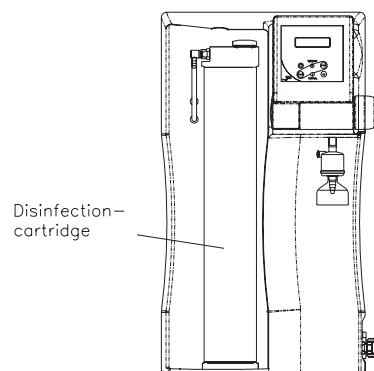

14. Faults – Causes - Remedies

Fault	Cause	Remedy
System does not start	<ul style="list-style-type: none"> - No power 	<ul style="list-style-type: none"> - Connect to power supply
No water can be dispensed	<ul style="list-style-type: none"> - Feedwater tap is closed - Feedwater and rinse water connections are the wrong way round - The feedwater pressure is < 0.1 bar 	<ul style="list-style-type: none"> - Open the feedwater tap - Re-connect them properly - Increase feedwater pressure
Conductivity > 0.055µS/cm	<ul style="list-style-type: none"> - System has a UF-module (higher conductivity can occur) - Ion exchange capacity is exhausted 	<ul style="list-style-type: none"> - Replace the Filter cartridge
Control no longer reacts	<ul style="list-style-type: none"> - Incorrect usage 	<ul style="list-style-type: none"> - Unplug the line plug for 5 seconds
Water leaks out	<ul style="list-style-type: none"> - Hose connections not watertight - Feedwater pressure > 6 bar 	<ul style="list-style-type: none"> - Check connections and make them leaktight - Install a downstream pressure reducer
Ultrapure water flow rate too low	<ul style="list-style-type: none"> - UF-Module is clogged - Too low a pre-pressure - Internal pressure too low 	<ul style="list-style-type: none"> - Replace the UF-module - Increase the pre-pressure - Re-adjust the pressure reducer
Wrong time or date	<ul style="list-style-type: none"> - Time difference - Time change 	<ul style="list-style-type: none"> - Reset the clock and the date
Wrong language	<ul style="list-style-type: none"> - wrong language setting 	<ul style="list-style-type: none"> - Correct the language setting
Fault message: "Limit value feed"	<ul style="list-style-type: none"> - Feedwater has too high a conductivity - Limiting value set too low 	<ul style="list-style-type: none"> - Check the pretreatment system - Check the limiting value setting and correct it

<p>Fault message: „Limit val. Pure w.“</p>	<ul style="list-style-type: none"> - Filter cartridge is exhausted - Limiting value set too low - The system has a UF-module (higher conductivity can occur) 	<ul style="list-style-type: none"> - Replace it with a new one (Art. No.: 09.2005) - Check the limiting value and re-adjust it
<p>Fault message: "UV duration"</p>	<ul style="list-style-type: none"> - The maximum operating hours of the UV-lamp have been exceeded 	<ul style="list-style-type: none"> - Replace the UV-lamp with a new one (Art. No. 09.2002) and re-set the operating hours counter to zero
<p>Fault message: "UV-Intensity"</p>	<ul style="list-style-type: none"> - Intensity to the UV-lamp is no longer sufficient - UV-Sensor is dirtied - Limiting value set too low 	<ul style="list-style-type: none"> - Replace the UV-lamp and measure maximum value - Clean the UV-sensor - Check and readjust the limiting value setting
<p>Fault message: "Max.temp."</p>	<ul style="list-style-type: none"> - The temperature in the system is too high - Pump interval time too long - Limiting value set too low - Feedwater temperature too high 	<ul style="list-style-type: none"> - Reduce the temperature by dispensing water - Reduce pump interval time - Check and readjust the limiting value setting - Reduce the feedwater temperature
<p>Fault message: "Meas cell LF1"</p>	<ul style="list-style-type: none"> - A break in the measuring cell cable - System control defect - Ultrapure water conductivity outside the measurement range 	<ul style="list-style-type: none"> - Replace the measuring cell - Replace the system control see "Conductivity > 0.055 μS/cm"
<p>Fault message: "Meas. cell LF2"</p>	<ul style="list-style-type: none"> - A break in the measuring cell cable - System control defect - Feedwater conductivity outside the measurement range 	<ul style="list-style-type: none"> - Replace the measuring cell - Replace the system control see Feedwater limiting value
<p>Fault message: "Meas. cell LF3"</p>	<ul style="list-style-type: none"> - A break in the measuring cell cable - System control defect 	<ul style="list-style-type: none"> - Replace the measuring cell - Replace the system control

Fault message: <i>"Temp. meas. cell."</i>	<ul style="list-style-type: none">- A break in the measuring cell cable- System control defect	<ul style="list-style-type: none">- Replace the measuring cell- Replace the system control
Fault message: <i>„change cartridge"</i>	<ul style="list-style-type: none">- Operating hours of the filter cartridge has expired	<ul style="list-style-type: none">- Replace it with a new one (Art. No.: 09.2005)

15. Replacement parts and consumables

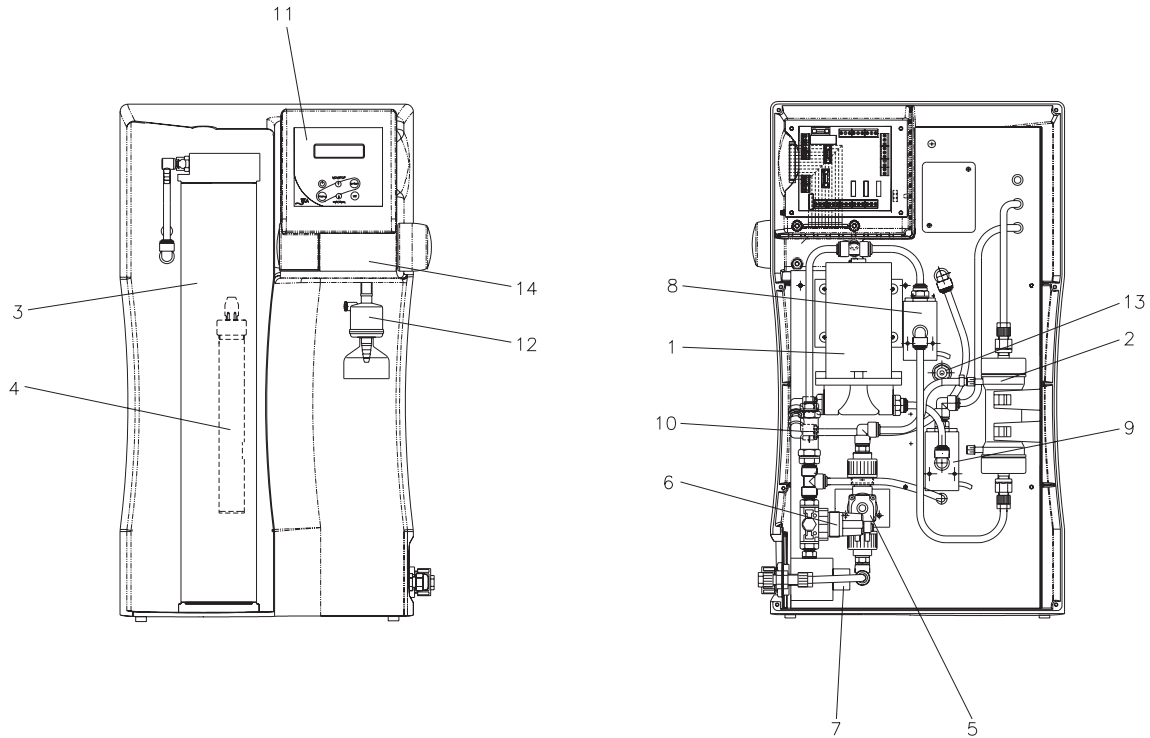

No.	Designation	Article- No.
1	Pressure boosting pump including transformer	19.0046*
2	Ultrafiltration module (optional)	22.0079
3	Filter cartridge	09.2005
4	UV-Reactor complete (optional) Replacement UV-lamp	26.0013 09.2002
5	Rinsing solenoid valve	15.0016*
6	Pressure reducer	15.0042
7	Feedwater conductivity measuring cell	16.0126
8	Ultrapure water conductivity measuring cell	26.0014
9	TOC conductivity measuring cell (optional)	26.0014
10	Check valve	15.0009
11	Microprocessor system control	26.0009
12	Sterile filter capsule, 0.2 µm, for dispensed water	09.1003
13	UV-Intensity sensor (optional)	16.0222
14	Dispensing valve	25.0068

* Wearing part



We ask for your understanding that we must declare the guarantee given for this system to be invalidated should replacement parts, accessories or consumables from other manufacturers be used, as we have no influence on their quality or appropriateness.

16. Accessories

Designation	Article- No.
Pretreatment	09.2000
Disinfection cartridge	09.2201
MICRO-Chlor disinfectant (packing to 12 container)	09.2202
Holder for externally-held system control	09.2209
Volume control for water dispensing	09.2210
Printer	09.2207
Qualification Manual DQ, IQ, OQ	09.2901

Distributed by:



Carl Stuart Limited

ADVANCED APPLIED TECHNOLOGIES

Contact Us:

Irl Ph: 01 4523432

UK Ph: 08452 30 40 30

Web: www.carlstuart.com

Email: info@carlstuart.com

17. Terminal assignment

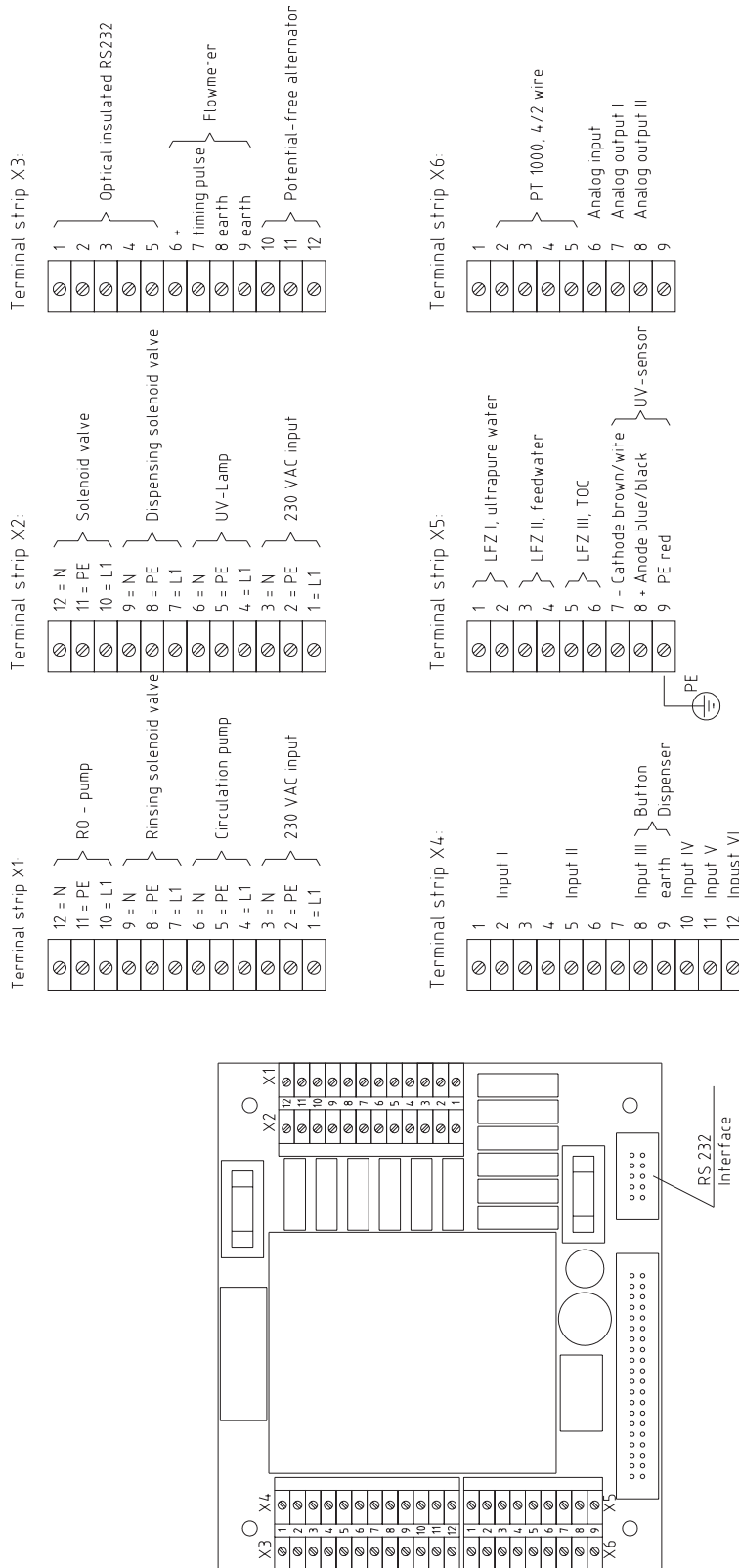

18. Maintenance record

(Please carefully keep this record, as complete and correct entries are a requirement for the validity of the guarantee)

Customer address: _____ Location: _____

_____ Type of system: _____

_____ Serial number: _____

_____ Year made: _____

Date	Feedwater conductivity [μS/cm]	Ultrapure water conductivity [μS/cm]	Ultrapure water flow rate [L/h]	Temperature [°C]	TOC-value [ppb]	UV-Intensity [%]	UV-Lamp operating hours [h]

Last change of Filter cartridge	Last cleaning / disinfection	Last change of pretreatment	Remarks	Signature

Any false entry is a falsification of documents.

The following points are to be observed to ensure maintenance of the quality of the system:

- 1x/ Weekly – record measured values
- Every 3 months – change the pre-treatment if available

For the optimal ultrapure water to be produced, the feedwater pre-treatment must be checked and subject to maintenance at regular intervals.